

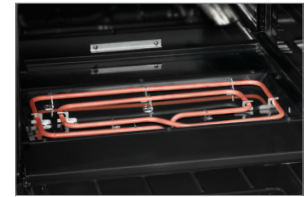

IR-6-E

Shown with optional casters

Model Numbers
IR-6-E
IR-6-E-C
IR-6-E-XB
IR-G36T-E



High performance 5.3 KW element provides even heating throughout the oven.

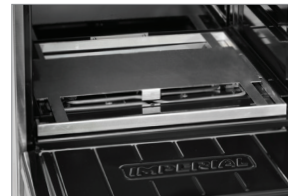

Splatter screen protects the element from spills.



9" (229) diameter round plate elements with easy to clean surface.

ROUND PLATE ELEMENTS

- 2 KW round plate elements with easy-to-clean flat surface.
- Provides a solid flat surface for fast, even heating.
- Plates are 9" (229) diameter for maximum pan contact.
- Solid top prevents spills from entering unit making clean-up easy.
- Infinite heat controls for maximum cooking flexibility.

GRIDDLE TOP

- Thick highly polished 3/4" (19 mm) steel plate with thermostat controls.
- 21" (533 mm) plate depth.
- Even heating elements across the griddle section provide consistent temperature across the plate.
- 4" (102 mm) wide grease trough and removable grease can for easy cleaning.
- Large griddle grease can is removable for easy cleaning.

STANDARD OVEN

- High performance 5.3 KW element provides even heating throughout the oven interior.
- Unique baffle above the element distributes heat flow to provide even cooking temperatures throughout the 5 KW oven. Splatter screen protects the element from spills.
- Chef depth standard oven interior accommodates standard 18" x 26" (457 x 660 mm) sheet pans front-to-back and side-by side.
- Oven is 26½" w x 26" d x 14" h (673 x 660 x 356 mm).
- Heavy duty thermostat with temperature range from 150°F to 500°F (65°C to 260°C).
- Porcelainized sides, rear, deck and door lining.
- Stamped inner door liner provides extra strength while optimizing heat retention.
- One chrome oven rack is included.

CONVECTION OVEN

- 5.3 KW convection oven with 1/4 hp blower motor cooks products quickly and evenly with less shrinkage.
- Convection oven interior dimensions 26-1/2" w x 22-1/2" d x 14" h (673 x 572 x 356 mm).
- Three position switch for cooking or cool down. Fan shuts off automatically when door is open.
- Porcelainized sides, rear, deck and door lining for easy cleaning.
- Three chrome oven racks included.



ELECTRIC

36" RANGES

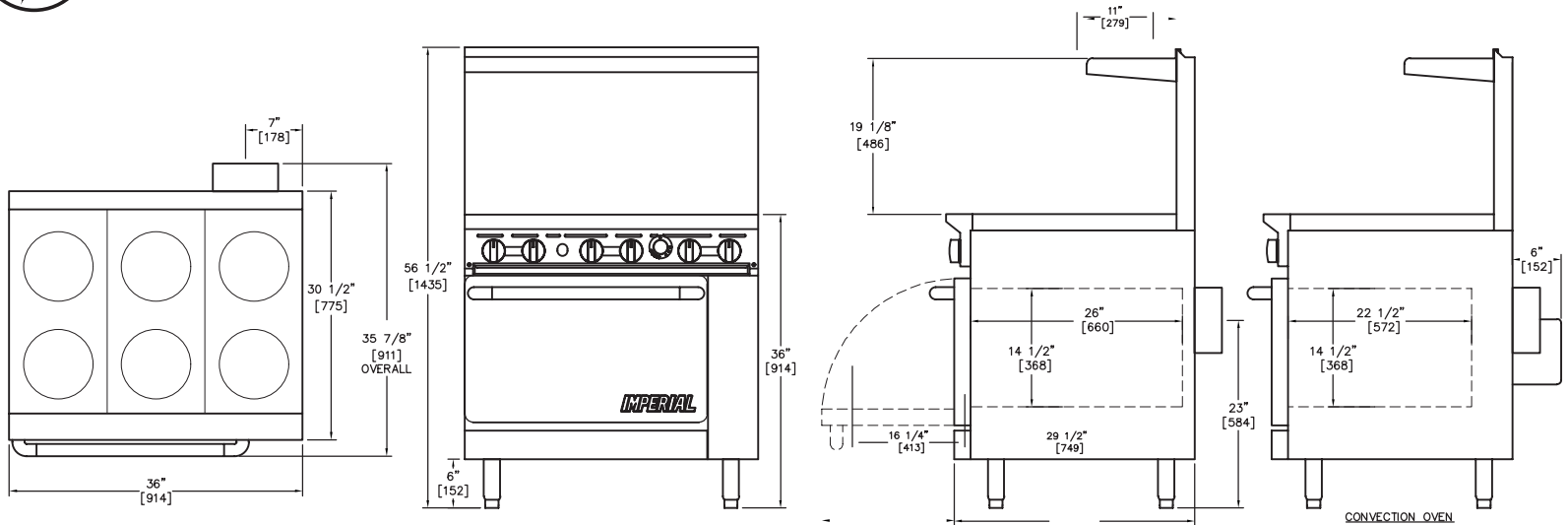

36" ELECTRIC RANGES

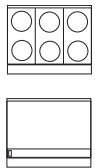

MODEL	ROUND ELEMENTS	GRIDDLE WIDTH	SHIP WEIGHT	
			KG	LBS
IR-6-E	6	N/A	274	605
IR-6-E-XB	6	N/A	247	545
IR-6-E-C	6	N/A	302	665
IR-G36T-E	N/A	36" (914 MM)	297	655

DIMENSIONS	CRATED DIMENSIONS
36" W X 31-1/4" D X 36" H* (914 X 794 X 914 MM)	38-1/2" W X 39" D X 35" H (978 X 991 X 889 MM)

EXTERIOR FEATURES

- Stainless steel front, sides, backguard, shelf, landing ledge and kick plate
- Welded and polished stainless steel seams.
- Large 4" (101 mm) stainless steel landing ledge
- 6" (152 mm) heavy duty legs with adjustable feet
- One year parts and labor warranty.

OPTIONS AND ACCESSORIES

- 6" (152 mm) stainless steel stub back, in lieu of standard backguard
- 11" (279 mm) stainless steel stub back, in lieu of standard backguard
- Reinforcement channels for mounting cheesemelter or salamander
- Extra oven racks
- Chrome griddle top
- 6" (152 mm) casters
- 480 volts, 3 phase

ELECTRICAL REQUIREMENTS				
MODEL	TOTAL KW	VOLTS	PH	AMPS
IR-6-E	17.3	208	1	84
	17.3	208	3	51
	17.3	240	1	72
	17.3	240	3	44
	17.3	480*	3	22
IR-6-E-XB	12	208	1	58
	12	208	3	38
	12	240	1	50
	12	240	3	33
	12	480*	3	17
IR-6-E-C	17.3	208	1	91
	17.3	208	3	58
	17.3	240	1	79
	17.3	240	3	51
	17.3	480*	3	29
IR-G36T-E	14.3	208	1	69
	14.3	208	3	42
	14.3	240	1	60
	14.3	240	3	36
	14.3	480*	3	18

Available in 208 and 240 volts, 1 and 3 phase.
Please indicate at time of order

CLEARANCE REQUIREMENTS

For use only on non-combustible floors. Legs or casters are required for non-combustible floors; or 2" (51 mm) overhang is required when curb mounted. Provide 0" clearance from non-combustible surfaces and 6" (152 mm) from combustible surfaces.

